

data: the power to take control

intelligent
measurement
monitoring
accuracy

IC 995

Electrical
Network
Analyser



Installation and Operating Manual

1. Overview

The IC 995 is the latest in the developing range of IC 900 Series Information Centres. In addition to the standard measured features of its predecessors, the IC 995 breaks new ground. Its large graphic display enables tabulated, bar and line graphs of Harmonic content, making the IC 995 a true engineering network analyser.

Built-in Modbus Communication, Voltfree Pulsed output, programmable Digital inputs and outputs ensure simple, accurate, remote monitoring of data, particularly when used in conjunction with the Autometers Horizon Monitoring System.

User-friendly installation, programming and operation make the IC 995 the choice of installers, operators and engineers alike. This, combined with Protocol compatibility across the Autometers Range, ensures that network communication remains one of the key strengths of the Information Centre Range.

Autometers Information Centres - Simple, Reliable, Accurate.

Product development is continuous and Autometers Systems Ltd reserves the right to make alterations and manufacture without notice. Products as delivered may therefore differ from the descriptions and illustrations in this publication.

Publication No. IC995.01.09.09

AUTOMETERS

SYSTEMS

Autometers Systems Limited,
4B Albany Road,
Chorlton-cum-Hardy,
Manchester.
M21 0AW

Tel: +44 (0) 161 861 9056
Fax: +44 (0) 161 881 3745
www.autometers.co.uk
Email: sales@autometers.co.uk

AUTOMETERS

SYSTEMS

visit us at www.autometers.co.uk

2. Functionality

1. Multi-function: accurately measures phase voltages, line voltages, line currents, active, reactive and apparent power, phase and total power factors, frequency and maximum demand.

2. Harmonics: the IC995 measures component harmonics up to the 31st inst and THD for both current and voltage.

3. Network analysis: displays 4-quadrant energies, including active capacitive energy, active inductive energy, reactive capacitive energy and reactive inductive energy. Also measures current "K" factor, voltage crest factor, waveform factor and degree of voltage and current imbalance.

4. Inputs/Outputs: the IC995 is provided with 4 digital inputs, 2 digital relay outputs, 1 volt-free pulse output (set at 10kWh/pulse) and 1 RS485 (Modbus protocol) output in order to satisfy remote meter reading and system control monitoring.

3. Technical features

FEATURE	VALUES	
INPUT	Network	1PH2W, 3P3W, 3P4W
	Frequency	45~65Hz
INPUT	Voltage	Normal: AC 100V, 400V Overloading: 600V (continuous); 1000V / 30s Consumption: < 0.2VA
	Current	Normal: AC 1A, 5A Overloading: 6A(continuous); 50A /1s Consumption: < 0.2VA
		Pulse output
Communication	RS485 (Modbus-RTU)	
Digital input (DI)	4 drying contact inputs, with +5V power	
Digital output (DO)	Mode: 2 NO contacts (AC 250V/3A, DC 30V/3A)	
Accuracy	Frequency 0.01Hz, reactive energy 1 class, others 0.5 class	
Display	LCD with backlight	
Power supply	AC/DC 85~270V; consumption: ≤4VA	
Isolation	Power / current input / voltage input: AC2kV/1min;	
	Power / Digital inputs / RS485: AC1.5kV/1min; Inputs / outputs / housing >5M _Ω	
Environment	Working T: -10C~+45C; Storing T: -20C~+70C	
	Relative humidity: 5%~95% Non-Condensing; Altitude: ≤2500m	
Material used	Polycarbonate v.0 rated	

The IC 995 meter is manufactured in compliance to:

EN 62052-11: 2004 (AC) General requirements
EN 62053-21: 2003 (Particular requirements part 21 static meters)

EN61010:2001 LVD approval



Dimensions

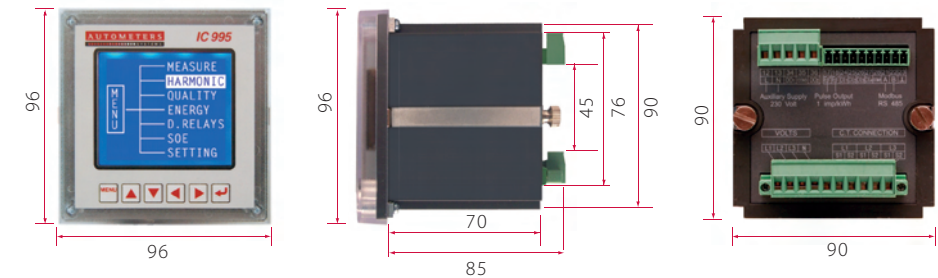

Connection Diagram 3 phase 4 wire, 230/400v 50Hz

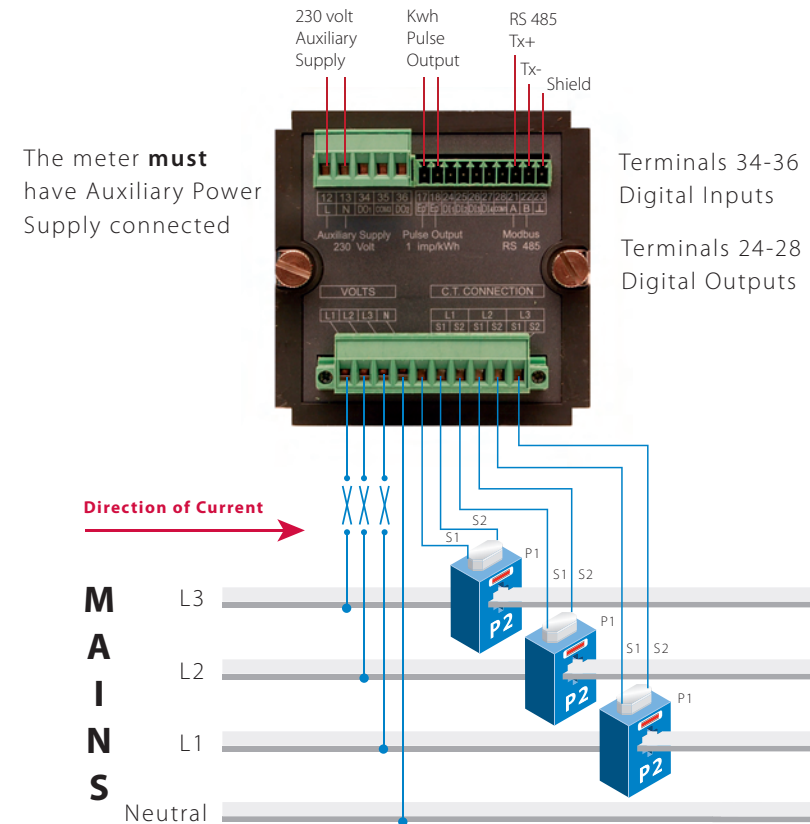

* it is important P2 faces the Load side

4. Installation and wiring requirements

4.1 Installation

IC995 is a 96mm square panel mounted meter and is installed by inserting the back of the meter through a hole in the front cover plate and locking it in position by two metal fixing clips which can be adjusted on the back. *See diagram below.*

4.2 Installing the IC 995

1. Create an opening on the switchboard of 92 x 92 mm.
2. Remove the IC 995 from the box, undo and remove the two metal fixing clamps on the back.
3. Taking the meter in your hand. Insert the meter through the hole in the front plate, slide the two metal fixing clamps down the side and screw the fixing screws tightly. This should now have secured the meter into the panel.

Power Supply

Power supply auxiliary terminals (12 + 13) AC/DC 85-270v

Wiring

Electrical and communication connections are made directly to the back of the meter. *See diagram to right.*

There are three blocks of green connectors, the two at the top can be unplugged, the one at the bottom is screwed into position. This connector terminates the current transformers into the meter and should not be unplugged unless necessary.

This connector can only be removed if the current transformers have been shorted out. These connectors should not be removed with power still on the meter. Choosing the correct cable to be used for the wiring of the current transformers to the meter depends on the rating of the current transformers used and the distance the current transformers are from the meter.

E.g. if the current transformers are minimum 2.5 va and are within 2 metres of the IC 995 then we recommend 1.5 multi stranded cable (Autometers Part number 995CH).

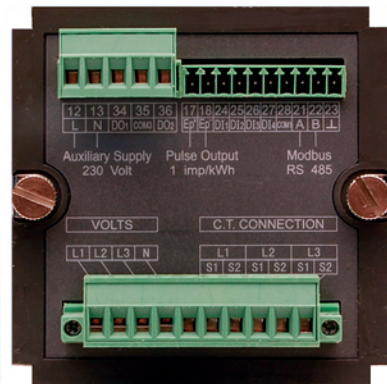

Picture showing the back of the IC 995 indicating the terminal numbers and the connectors.

Please note that one of the top terminal connector blocks has been removed.

4.3.1 Upper Connectors

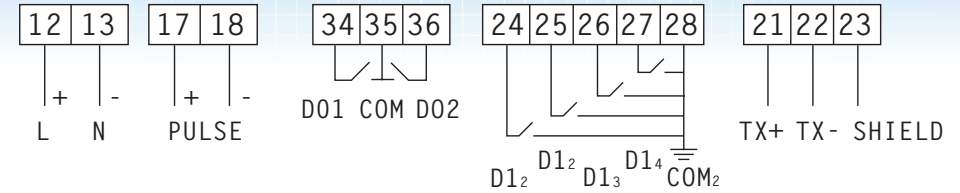

4.3.2 Lower Connections

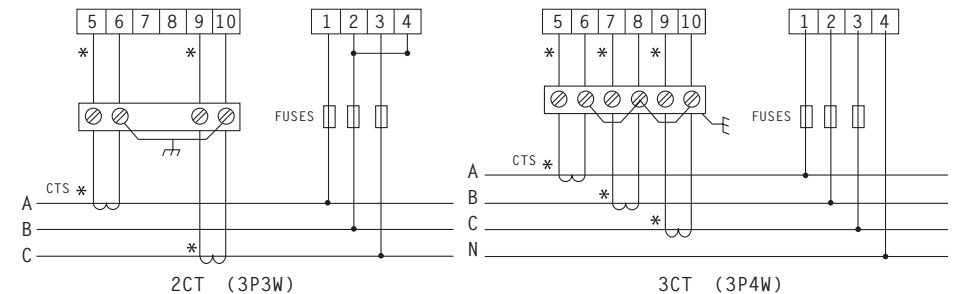
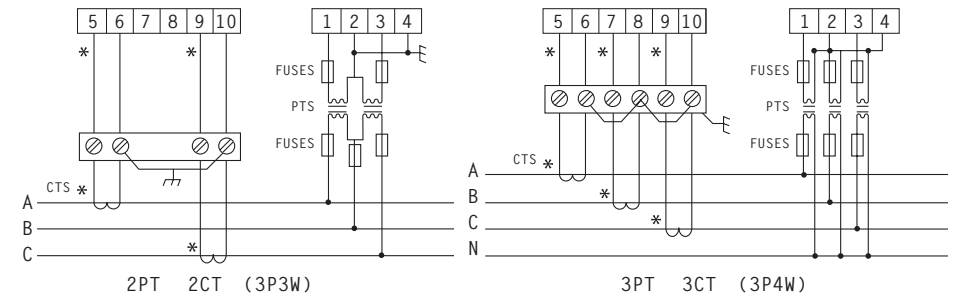

5. Package

The meter comes boxed. Inside the box there should be the IC995 meter, 3 sets of green connectors and two fixing brackets. An installation manual is supplied separately with the box.

On opening the package, please check it carefully. If there is any damage, please contact Autometers directly, or our dealers, as soon as possible and keep the damaged package intact.

6. Installation

6.1 Voltage Input

Voltage input should be less than 120% normal voltage (100V or 400V), otherwise please use PT. On the voltage input, please use a 1Amp fuse. The wiring should be as our diagrams on page 5.

Mode of wiring

1 element	1P2W
2 element	3P3W
3 element	3P4W

Match the voltage input with current input, and match the phase and phase sequence (otherwise the values or signals will be incorrect).

6.2 Current Input

Normal current input is 5A, for more than 5A you must use Current transformers. Make sure that you follow the connection details carefully when connecting the voltage and current circuits to the meter.

6.3 Installation of Current Transformer

It is good practice to use a test shorting block where the external current transformers can be linked out should the meter ever need replacing.

6.4 RS485 Modbus Wiring

The IC 995 is fitted with an RS 485 Modbus output. It has been designed to work with Autometers protocol version V6.2.17, which enables up to 128 meters to be connected on one Lan circuit. We advise using Beldon cable 9841 or 9842.

7. Features available

7.1 Main menu:

When the meter has voltage applied to the auxiliary terminals (12 and 13) the meter will go through a set up routine. Firstly the display will show Autometers' front page then it will go to the first screen (01), the line voltage screen.

Press Menu to view the various optional parameters.

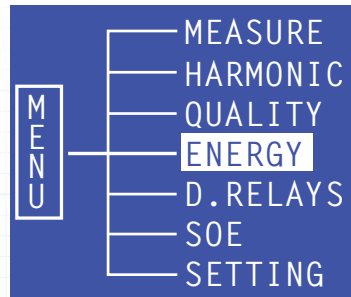

- MEASURE:** displays Line voltage, Phase to Phase, Line Current, Instantaneous power, Power factor, Total power and Max demand
- HARMONIC:** displays Current and Voltage harmonic data to the 31st inst, waveform showing comparison of voltage and current and bar graph comparing voltage and current
- QUALITY:** displays Crest factor, THFF, K Factor, Unbalanced factor Voltage peak, Voltage vector, Current vector
- ENERGY:** displays Import and Export of Kwh, Kvarh and import of Kvah
- D.RELAYS:** indicates status of digital relays
- SOE:** displays time and date of relays which have been activated
- SETTING:** programming of meter parameters

Selecting Individual parameters

Select Menu: Move the highlighted feature up or down by pressing the arrows marked to the parameters you want to view.

7.2 MEASURE: Press the return key this will take you to the Line voltage screen. Press the down key to view individual parameters.

01. Phase to Neutral volts
02. Phase to Phase voltage
03. Phase and Total current
04. Instantaneous Kw
05. Instantaneous Kvar
06. Instantaneous Kva
07. Individual phase Power factor and Total Power factor
08. Total Instantaneous power Kw, Kvar, kva and Total Power factor
09. Maximum Demand

Volts		01
L1	220.0	V
L2	220.0	V
L3	220.0	V
F	50.00	Hz
08-14-2009		17:45:55

01. Phase to Neutral volts

Volts		02
L1-2	381.0	V
L2-3	381.5	V
L3-1	381.5	V
F	50.00	Hz
08-14-2009		17:46:15

02. Phase to Phase voltage

AMPS		03
L1	04.99	A
L2	04.99	A
L3	04.99	A
TTL	14.99	A
08-14-2009		17:56:11

03. Phase and Total current

Inst Power		04
L1	1.100	Kw
L2	1.100	Kw
L3	1.100	Kw
TTL	3.300	Kw
08-14-2009		17:56:26

04. Instantaneous Kw

Inst Power		05
L1	0.001	Kvar
L2	0.001	Kvar
L3	0.000	Kvar
TTL	0.003	Kvar
08-14-2009		17:56:37

05. Instantaneous Kvar

Inst Power		06
L1	1.099	Kva
L2	1.099	Kva
L3	1.098	Kva
TTL	3.297	Kva
08-14-2009		17:56:37

06. Instantaneous Kva

Power Factor		07
L1	1.000	
L2	1.000	
L3	1.000	
TTL	1.000	
08-14-2009		17:56:57

07. Individual Phase Power Factor and Total Power Factor

Total Power		08
	3.300	Kw
	0.003	Kvar
	3.297	Kva
PF	1.000	
08-14-2009		17:57:06

08. Total Instantaneous Power Kw, Kvar, kva and Total Power Factor

Max Demand		09
PEAK Kw	= 3.266	
	09-15 12:02	
PEAK Kvar	= 3.038	
	09-15 12:01	
PEAK Kva	= 3.270	
	09-15 12:02	
08-14-2009		17:57:16

09. Max Demand with Date & Time

HARMONIC: Press the key with the arrow facing down \blacktriangledown to move the cursor down and highlight harmonic. Press return \blackrightrightarrows to view individual parameters.

Here you will have a selection:

- VALUE** (diagram 1)
- WAVEFORM** (diagram 2)
- BAR** (diagram 3)

VALUE: To select "VALUE" move the cursor over the word "Value" by pressing the key with the arrow facing down and then press return \blackrightrightarrows . Here you will be able to view the individual line voltages to the 31st Inst. By continually pressing the \blacktriangledown you will be able to view the individual current to the 31st Inst and THD of both voltage and current.

%	VL1	VL2	VL3
03	00.00	00.00	00.00
05	00.00	00.00	00.00
07	00.00	00.00	00.00
09	00.00	00.00	00.00
11	00.00	00.00	00.00
13	00.00	00.00	00.00

diagram 1

WAVEFORM: To select "WAVE FORM" move the cursor over the word "Waveform" by pressing the key with the arrow facing down \blacktriangledown and then press return \blackrightrightarrows . Here you will be able to view the individual line voltages to the 31st Inst. By continually pressing the \blacktriangledown you will be able to view the individual current to the 31st Inst and THD of both voltage and current.

BAR: To select "BAR" move the cursor over the word "Bar" by pressing the key with the arrow facing down \blacktriangledown and then press return \blackrightrightarrows . Here you will be able to view the individual line voltages to the 31st Inst. By continually pressing the \blacktriangledown you will be able to view the individual current to the 31st Inst and THD of both voltage and current.

7.4 QUALITY (Quality of network)

Select Menu: Move the highlighted feature up or down by pressing the arrows marked \blacktriangle \blacktriangledown to the "Quality" line.

Quality: Press the return key \blackrightrightarrows this will take you to the Crest factor (01). Press the down key \blacktriangledown to view individual parameters available.

- 01. Crest Factor
- 02. THFF
- 03. K. Factor
- 04. Unbalanced Factor
- 05. V. Peak
- 06. V. Vector
- 07. I. Vector

CREST FACTOR: The Crest Factor is equal to the peak amplitude of a waveform divided by the RMS value. The purpose of the crest factor calculation is to give an analyst a quick idea of how much impacting is occurring in a waveform.

The screen displays: V1, V2, V3.

THFF (Telephone Harmonic Form Factor):

The harmonic interference may cause noise in the system and influence the quality of communication; our hearing and the telephone cannot respond well to the 50Hz current and voltage but can respond better to about 1KHz current and voltage. In Europe, CCITT detects harmonic interference to telecom with Pn, then figures it with THFF. It is 0 with no harmonic.

The Screen displays: V1, V2, V3.

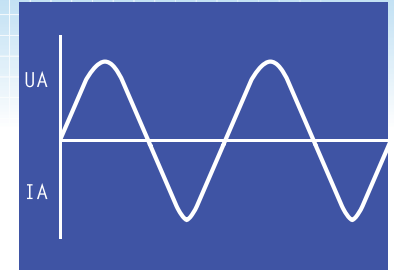

diagram 2

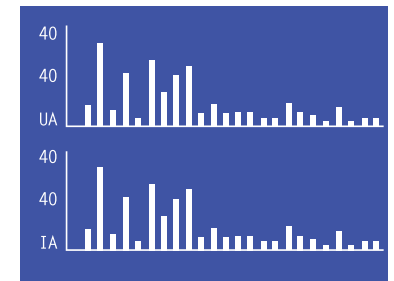

diagram 3

CREST FACTOR		01
V1	1.628	
V2	1.621	
V3	1.636	
08-14-2009		17:56 57

THFF		02
V1	00.80	%
V2	00.74	%
V3	00.72	%
08-14-2009		17:56 57

K FACTOR: (Current K Factor)

K-factor is a weighting of the harmonic load currents according to their effects on transformer heating, as derived from ANSI/IEEE C57.110. A K-factor of 1.0 indicates a linear load (no harmonics). The higher the K-factor, the greater the harmonic heating effects.

The screen displays: I1, I2, I3.

K FACTOR		03
I1	00.00	
I2	00.00	
I3	00.00	
08-14-2009		17:56:11

UNBAL FACTOR: (Unbalance Factor)

To look at the current and voltage unbalance factor. In a 3-phase distribution, if the current or voltage RMS are not the same or the difference between a 3 phase angle is not 120 degrees, we call the phase voltages or current 'unbalance'. The unbalance voltage or current of 3-phase can be divided into positive component, negative component and zero component.

The screen displays:

UNBAL FACTOR		04
Vuf	002.6	%
Iuf	002.2	%
08-14-2009		17:56 57

Vu f % (Voltage unbalanced factor),

Iuf % (Current unbalanced factor)

V PEAK: (The Peak Voltage)

Peak voltage is the highest level of volts from an alternating current. For example, in the UK the mains supply to a house is 230RMS. 230 volts is the average (simplified) you will get from the AC supply. But in reality the AC wave switches between -320 and 320 volts. So 320 is the peak voltage.

To find out the peak voltage of an alternating current you must multiply the RMS voltage by root2 or 0.707 (this works only when the AC signal is a sine wave).

The screen displays: V1,V2,V3.

V PEAK		05
L1	335.5	
L2	334.8	
L3	331.4	
08-14-2009		17:56 57

V VECTOR: (The Voltage Vector)

Widely-used in European standards, the first definition originates from the theory of Symmetrical Components which mathematically breaks down an unbalanced system into three balanced systems as shown.

V VECTOR		06
+	230.2	
-	059.6	
N	030.0	
08-14-2009		17:56 57

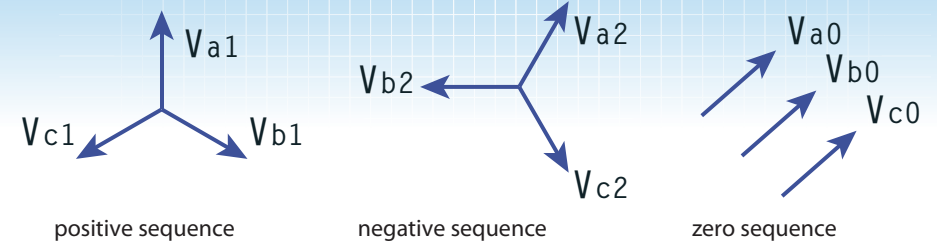

These three are called positive sequence, negative and zero sequence systems. For a perfectly balanced system both negative and zero sequence systems would be absent.

The screen displays: +V1, -V2, N.

I VECTOR: (The current vector)

To look at the positive component, negative component and zero component.

The Screen displays: +I1, -I2, N.

I VECTOR		07
+	0.094	A
-	0.002	A
N	0.000	A
08-14-2009		17:56 57

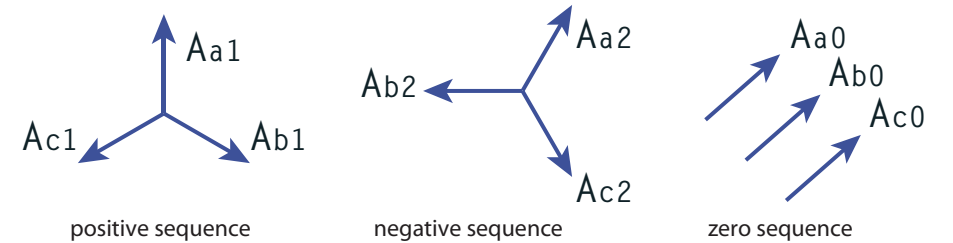

7.5: Energy

Select Menu: Move the highlighted feature up or down by pressing the arrows marked \blacktriangle \blacktriangledown to the "Energy" line.

Energy: Press the return key \blacktriangleright this will take you to the Energy screen (only one screen).



The screen displays: Import and Export Kwh, Kvarh and Import Kvah.

ENERGY	
0000005.67	+kwh
0000000.00	+kvarh
0000002.02	kvah
0000005.67	-kwh
0000005.67	-kvarh
08-14-2009 17:56:57	

7.6 D.RELAYS (Digital relay output)

This screen shows the status of the digital inputs and outputs relays. The digital input is powered by +5V, and digital output is a pair of non-powered contacts. If programmed, the status will change to "ON": these relays are mainly used in building management systems.

7.7 SOE (SEQUENCE OF EVENTS)

Select Menu: Move the highlighted feature up or down by pressing the arrows marked   to the "SOE" line.

Press the return key , this will take you to the S.O.E. screen (only one screen).

SOE: Captures the time the digital relays have been activated.



The picture shows three events which have occurred, but by scrolling down using the key with the arrow facing down  up to 16 events can be captured.

The top two lines are the last activation of the relay.

This indicates: Digital Output 1 was activated 22nd October 2009 at 12 hours, 20 minutes, 55 seconds. This was returning to normal status.

01	D01	2009-10-22
	NO	12-20-55
02	D01	2009-10-22
	NC	12-12-20

The second event shows: Digital Output 1 was first activated on 22nd October 2009 at 12 hours, 12 minutes, 20 seconds (sounding the alarm).

Select Menu: Move the highlighted feature up or down by pressing the arrows marked   to the "SOE".



S.O.E. Press the return key .

This indicates the time and date of any relay which has been activated.

7.8 SETTING (User Setting)

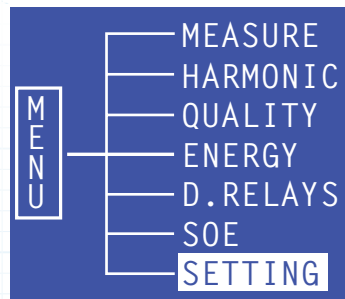
This is used for programming the meter, great care should be taken here to ensure you enter the correct details.





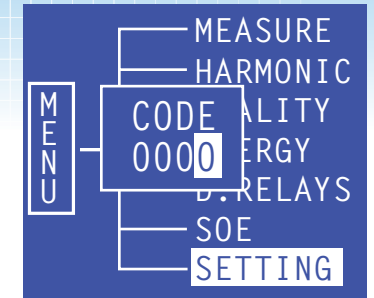

Select MENU: Move the highlighted feature up or down by pressing the arrows marked   to "SETTING".

SETTING: Press the return key  this will take you to the Code "0000".

There is a security level here which must be entered to allow you to program the meter. The default password is "0001"





Enter the PASSWORD 0001 by pressing the keys with the four arrows on    .

The two keys which have the arrows pointing up and down   move the cursor along for you to enter your number in the correct sequence. The two keys with arrows pointing left and right   increment the number up or down. When you have selected the correct number press the return key .

This will now take you to the "CONFIG SCREEN".

Here is listed a small menu.

CONFIG (programmes the vt and ct ratio)
 RS485
 PASSWORD
 TIME
 D.Relays

Select Menu: Move the highlighted feature up or down by pressing the arrows marked   to the "CONFIG" line.





CONFIG. Press the return key  this will take you to the Configuration screen.

- A. Network: This can be set to, 1 phase 2 wire, 3 phase 3 wire, 3 phase 4 wire.
- B. V Range: This can be set at 100 volt or 400 volt
- C. I Range: This can be set at 1 amp or 5 amp
- D. PT: This can be set at Voltage ratio range
- E. CT: This can be set at any current transformer ratio.



E.g. programming the meter to be on a 3 phase 4 wire network 230/400 volt, 50 Hz, 200/5 amp.

CONFIG	
NETWORK	3P4W
U RANGE	400V
I RANGE	5A
PT	0400/0400
CT	4000/0005
SN	429496
08-14-2009 17:57:16	



Network:

Move the highlighted feature up or down by pressing the arrows marked   to the "Network" line. The cursor will move over the "3p4w" symbol to alter this press the key with the arrows facing the right  this will switch from 1p2w to 3p3w to 3p4w. Select the value you want then press the key with the arrow facing down , this moves the cursor to the line below.



V. Range:



You will notice that the 400 v is now highlighted. To change this press the arrow key marked with the arrow pointing to the right  the number will change to 100V. select the voltage range you require and then press the key with the arrow marked down . You will notice the 5A is now highlighted.

I. Range:

To change I range press the arrow key marked with the arrow pointing to the right , the number will change to IA. Select the setting you require and then press the key with the arrow marked down . You will notice the 0400/0400 is now highlighted.



VT: To change this you will need to operate four keys    .



The two keys which have the arrows pointing up and down   move the cursor along for you to enter your number in the correct sequence.



The two keys with arrows pointing left and right   increment the number up or down.

E.g. The cursor will move down over the first number to your left, to move this across to the next cursor press the key with the arrow facing down  the cursor has now moved one space to the right. To increment the number at any point press the key with the arrow marked to the right. Continue until you have entered the correct numbers.





0400/0400 select the voltage range you require and then press the key with the arrow marked down . You will notice the 0005/0005 is now highlighted.

C.T. (current transformer ratio): To change this you will need to operate four keys    .

The two keys which have the arrows pointing up and down   move the cursor along for you to enter your number in the correct sequence.

The two keys with arrows pointing left and right   increment the number up or down.

E.g. The cursor will move down over the first number to your left, to move this across to the next cursor press the key with the arrow facing down  the cursor has now moved one space to the right. To increment the number at any point press the key with the arrow marked to the right. Continue until you have entered the correct numbers: 0200/0005.



You must now press the return key  this will set all the parameters you have chosen in the meter. a box will appear with yes/no in it . Press the key with the arrow facing left  the cursor has now moved over the "YES". Press return  this has now programmed the ct ratio.

IMPORTANT : *You will receive the meter in the factory default mode which is suitable for 3 phase 4 wire network, 230/400 volt, 50 hz 0005/0005 amp.*

YOU SHOULD ONLY NEED TO PROGRAM THE CT RATIO AND THE TIME INTO THE METER

E.g: 0200/0005 (the date and time)

Select Menu: You should now be back at the Config Menu:

Move the highlighted feature up or down by pressing the arrows marked up or down   to the "RS 485" line.

RS 485: Press the return key  this will take you to the RS 485 screen. Here you have two features you can alter.

a. Address (meter's unique Modbus number)

b. Baud Rate

a. Address



Please note the meter is factory-set to match Autometers protocol.

Baud Rate:	9600	Data Format:	Floating point
Parity Type:	Even	Modbus Type:	RTU
Wire Mode:	2 wire	F.P. High word first	

When using RS 485 Modbus it is vital that you understand what management system the meters will be connected to. Normally every meter must have a unique address and must not be duplicated.

However, when connecting to Autometers Intelligent Termination Point then all meters must have the address set at "001".

To change this you will need to operate four keys    .

The two keys which have the arrows pointing up and down   move the cursor along from left to right so you can enter your number in the correct sequence.

The two keys with arrows pointing left and right ◀ ▶ increment the number up or down.

E.g. The address number is highlighted with the first number on the left "001", to change this to "015" read below.

First press the key with the arrow pointing down ▼ this will move the cursor one stop to the right. Now press the key with the arrow pointing to the right ▶ this will increment the number stop when you reach 1, now press the key with the arrow pointing down ▼ this will move the cursor one stop to the right. Now press the key with the arrow facing to the right, this will increment the number stop when you get to number 5 now the numbers should look like "015" press the key marked with the arrow facing down, The cursor has now dropped to the level below.

b. Baud Rate:

This is normally defaulted to 9600 and works with almost all management systems. If, however, you want to change this you have five choices 2400, 4800, 9600, 19200 and 38400.

To alter to the new settings press the key with the arrow marked facing the right ▶ this will scroll through your choices, stop at the correct one.

Now you have set the address and baud rate. To program into the meter you must press the return key ↵ you will notice that a box appears which has "YES" "NO". Press the key with the arrow facing to the left ◀, you have now highlighted the "YES" press return ↵, you have now set the parameters. Press "Menu" to return to Config list.

PASSWORD: To alter the password.

The meter has been designed for customers or companies to have their own individual password protection. To alter the password first take the steps of writing down your chosen password and keeping it in a secure place.

Press the key with the arrow facing down ▼, this should now highlight the word "PASSWORD" press return ↵.

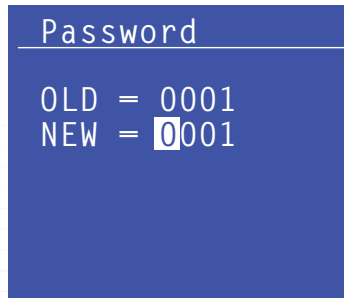

You will notice on the display screen "old 0001" and on the line below "New". You will notice that the cursor is already positioned on the first "0" for you to alter the number. Press the key with the arrow facing down ▼ to move the cursor to the right and the key with the arrow to the right ▶ to increment the number.

When you have entered your new number in press return ↵. A box will appear with "YES NO" YES NO. Move the cursor over the the left by pressing the key with the arrow facing left ◀. Press Menu to return you to Config screen.

TARRIF: Please note this is NOT activated in this meter.

TIME:

Press the key with the arrow facing down ▼ until the Time is highlighted. Press return ↵, this takes you into Time screen. The cursor will now be over the first digit to the left (the date). Using the key with the arrow facing the right ▶ this will increment the number. Press the key with the arrow facing down ▼ to move the cursor one step to the right and again press the key with the arrow facing the right ▶ to increment. Repeat this until the date is complete. When the last digit to the right has been entered press the key with the arrow facing down ▼ this will drop the cursor down to the time. Repeat using the keys as above until the time has been entered. When the time has been completed press return ↵.

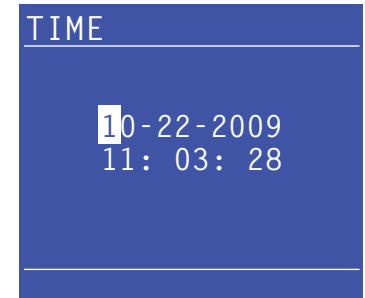

A box will appear with "YES" and "No" in it YES NO, press the key with the arrow facing left ◀ the cursor has now moved over the "YES". Press return ↵ this has now programmed the time.

Press Menu. This returns you to config screen.

D.RELAYS: SETTING

Press the key with the arrow facing down ▼. This now moves you down and has highlighted Switching. Press return ↵.

This takes you to the "D RELAYS" programming section, you will notice on the display that there are numbers 1 and 2. This is because there are two output relays.

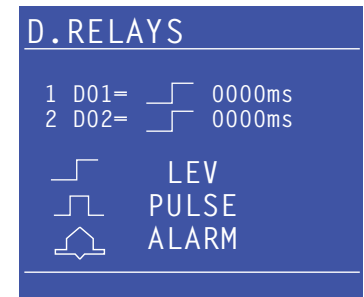

Digital output 1: Can be configured to 3 positions: Level, Pulse or Alarm.

Digital output 2: Can be configured to only 2 positions: Level and Pulse.

Level means: the internal relay of the ic 995 is operated by an external pc enabling a contactor or breaker to be switched open circuit.

Pulse: digital input signal from an external contactor/breaker to the meter, this is normally read by a building management system via Modbus.

ALARM: The alarm is seen as a bell on the display and can be programmed to Over Voltage, Under Voltage, Over Current, the Unbalance of currents and Voltage alarms. Opens and closes a relay for a set time.

Programming the switching configuration on DO1 and DO2. The cursor will be over the "level" indicator, to alter this to pulse or alarm press the key with the arrow to the right this will scroll through the options. When you have selected your option, press the key with the arrow facing down this will move the cursor to the four digits on the left. "0000" this is the time the relay will stay open or closed and is based in milli seconds. Use the key with the arrow facing right to increment the numbers. Use the key with the arrow facing down to move the cursor to the right.

When you have reached the last position in the digits on line 1 press the key with the arrow facing right this will move the cursor down to the 2nd line. This line represents Digital output 2. Repeat above to program this output.

When you have programmed the digital outputs press Return . A box will appear on the screen with "YES" and "NO" press the cursor with the arrow facing left so the "YES" is highlighted. Press return .

Press Menu.

ALARM: This is used for setting the value you want the alarm to be activated.

You will see on the screen 5 options where you can input values to set an alarm. When this value has been reached a relay will close or open.

V	>	000.0	Over Voltage
V	<	000.0	Under Voltage
I	>	0.000	Over Current
Vuf	<	000.0	Unbalance of Current
Iuf	<	000.0	Unbalance of Voltage

ALARM		
U	<	000.0
U	>	000.0
I	>	0.000
VUF	>	000.0
IUF	>	000.0

The cursor will be positioned on the first "0" on the top line (Over voltage) press the key with the arrow facing right to increment or press key with arrow facing down to move the cursor one step to the right. Repeat until you have completed your programming.

Repeat above to program the other values as listed on the display.

When you have programmed the alarm outputs press return . A box will appear on the screen with "YES" and "NO" press the cursor with the arrow facing left so the "YES" is highlighted. Press return .

Press Menu.

Press the key with the arrow facing down . This now moves you down and has highlighted "OTHERS". Press return .

OTHERS: This is used for resetting registers back to zero.

You will see on the display a small menu.

CLR.E:	OFF	YES - resets the energy registers to zero
CLR.S:	OFF	YES - resets the time stamps in the S.O.E.
CLR.MD:	OFF	YES - resets the maximum demand back to zero
BACKLIGHT:	OFF	YES - turns backlight permanently on
CONTRAST:	50	This allows adjustment on the contrast of the display 0-55

OTHERS	
CLR.E	NO
CLR.S	YES
CLR.MD	OFF
BACKLIGHT	OFF
CONTRAST	45

You will notice that the cursor has highlighted the "OFF" position on the CLR.E on the display. To change this to "YES" press return key this brings up a box with "YES" "NO" . Move the cursor to "YES" by pressing the key with the arrow marked on the left then press return this takes you back to "OTHERS" screen.

Repeat above to adjust other options.

Press Menu to return to CONFIG screen.

Press Menu again to return to main menu.

NOTE: When in the OFF position, the backlight allows a view time of 40 seconds before switching off. Continually pressing the return key when you are operating the meter will keep on extending the illumination of the display by 40 seconds.

If you switch the backlight permanently ON then please be aware this will shorten the life of the display.