

MT171 Three-Phase Electronic Meter with External Time Switch

MT172 Three-Phase Electronic Meter with Internal Time Switch



OFGEM Approved & Certified

The MT172 three-phase electronic meters are designed for measuring and registration of active and reactive energy in three-phase four or three-wire network for direct and indirect connection. Measuring and technical characteristics of the meter comply with the IEC 62052-11 and IEC 62053-21 (IEC 61036) international standards for electronic active energy meters, class 1 or 2, and reactive energy meters, classes 2 and 3 in compliance with IEC 62053-23 as well as a standard for time switches IEC 62052-21.

The meters are designed and manufactured in compliance with the standards and ISO 9001 as well as more severe Iskraemeco standards.

Display

Display and Indications:

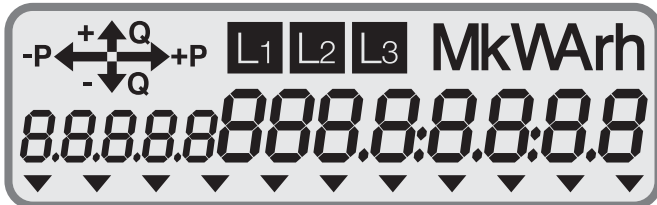

Fig.5 - Large Display

Measuring data are displayed with eight 7-segment 8mm high digits. Displayed data are identified with 5-digit EDIS code (DIN 43863-3), digits, are 7-segment and 5mm high.

Symbols indicating energy flow direction, valid tariffs as well as the meter statuses are also displayed on both displays.

• Quality

- High accuracy as well as long term stability of measurement.
- High reliability of operation and long lifetime (20 years).

• High immunity to EMC disturbances

• Simple and fast mounting

- **A compact plastic case**, made of high-quality self-extinguishing materials, assures high degree of protection against dust and water penetration (IP53)

Meter Characteristics

• Active Energy Meter

- Accuracy Class 1 or 2

• Reactive Energy Meter

- Accuracy Class 2 or 3

• Energy Measuring and Registration Modes

- Standard – As An Induction Meter
- Other Options:
 - Bi-Directional
 - Absolute (Always Positive)

• Connection To Network: A Three-Phase Meter Can Also Function As A Single-Phase Or A Two-Phase Meter

• One Or Multi-Tariff Registration (Up To 4 Tariffs) According To A Real Time Clock Or External Tariff Inputs:

• Display Modes On LCD:

- Automatic Data Scroll
- Manual (Triggered With A Key)

• Data Display On LCD In Voltage-Free State (Option)

• Indications

- LED1: Imp / kWh
- LED2: Imp / kVAr
- LCD: Presence of phase voltages L1 L2 L3
- Energy Flow Direction
- Active Rate Indication

• Inputs and Outputs

- Up To Two Pulse Outputs
- Up To Two Tariff Inputs

Technical Data

Accuracy Class	2 or 1
Basic Current I _b	5, 10, 15, 40 A
Max. Current I _{max}	40, 60, 85, 100, 125 A
Min. Current	0.05 I _b
Starting Current	0.005 I _b or 0.0004 I _b
Nominal Current	1, 5 A C.T. Operated
Max. Current I _{max}	6, 10 A C.T. Operated
Min. Current	0.02 I _n C.T. Operated
Starting Current	0.003 I _n or 0.002 I _n
Rated Voltage U _n	3x230/400 V
Voltage Range	0.8 U _n ... 1.15 U _n
Rated Frequency	50 Hz
Accuracy	(at 25°C)
RTC Control	Quartz Crystal 32 kHz
Operating Temperature Range	-25°C ... +60°C
Extended Operating Temperature Range	-40°C ... +60°C
Storing Temperature	-40°C ... +85°C
Current Circuit Burden	<0.5 VA
Dielectric Strength	<2 W / 10 VA
Impulse Voltage	6 kV, 1.2/50µs
Short-Circuit Current	30 I _{max}
EMC: High Frequency Disturbances (IEC 1000-4-4)	6 kV
Flame Class	V0 (Standard UL 94)
Dust and Water Protection	IP53
Optical Port	IEC62056-21 (IEC 61107)
Impulse Outputs:	
SO	t _i = 40 ms (on request from 10 to 160 ms)
Opto-MOS Relay	t _i = 40 ms (on request from 10 to 160 ms) Switching Power: 25 VA (100 mA, 250 V)
Dimensions (h x w x d)	250 x 178 x 55 mm
Mass	1 kg

Lifetime

The meter is designed for a 20-year lifetime at normal operating conditions.

Meter Connection Procedure

1. Place the meter to a connection position.

2. Connect the meter to network.

3. Check connection indication:

- LED is lit (load current is less than starting current)
- LED is blinking (proportional to lead current strength)

4. Check connection – see LCD indications: Display

- Presence of all three phases – L1 L2 L3, all symbols displayed,
- One phase failed – a symbol for the failed phase is not displayed
- Reversed phase sequence – L1 L2 L3 symbols of reverse connected phases are blinking.

Meter Case

The meter case is made of self-extinguishing polycarbonate that can be recycled.

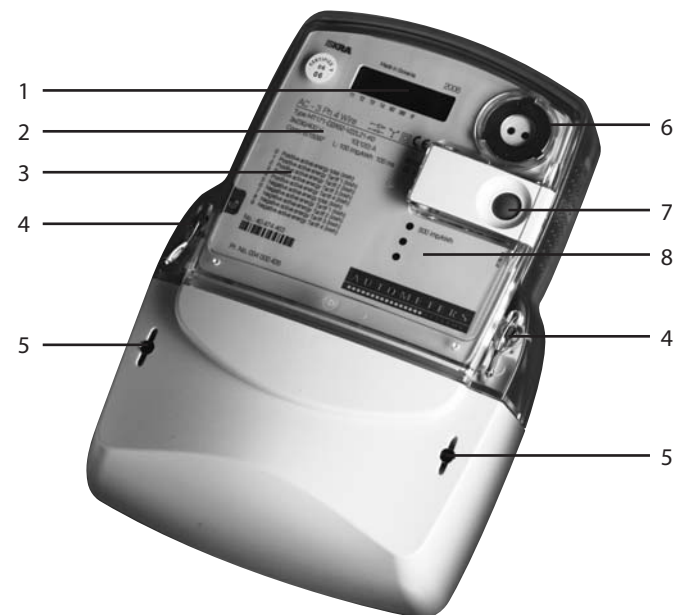

Fig.7 – Meter Constituent Parts

1. An LCD
2. Meter technical data
3. A legend of data identification codes
4. A meter cover sealing screw
5. A terminal cover sealing screw
6. An IR optical port
7. Scroll and Reset keys
8. An impulse LED

Data Display On LCD

Data that are defined in auto scroll and manual scroll sequences are displayed. Data are reviewed with a key or they are cyclically

CODE	DESCRIPTION
0.9.1	Time
0.9.2	Date YY-MM-DD
C.1.0	Manufacturing Number
0.0.0	Device Number
1.8.0	Positive Active Energy Total (A+)
1.8.1	Positive Active Energy Tariff 1 (T1)
1.8.2	Positive Active Energy Tariff 2 (T2)
1.8.3	Positive Active Energy Tariff 3 (T3)
1.8.4	Positive Active Energy Tariff 4 (T4)
15.8.0	Absolute Active Energy Total [kWh]
15.8.1	Absolute Active Energy Tariff 1, [kWh]
15.8.2	Absolute Active Energy Tariff 2, [kWh]
15.8.3	Absolute Active Energy Tariff 3, [kWh]
15.8.4	Absolute Active Energy Tariff 4, [kWh]
2.8.0	Negative Active Energy Total [kWh]
2.8.1	Negative Active Energy Tariff 1, [kWh]
2.8.2	Negative Active Energy Tariff 2, [kWh]
2.8.3	Negative Active Energy Tariff 3, [kWh]
2.8.4	Negative Active Energy Tariff 4, [kWh]
3.8.0	Reactive Energy Import Total
3.8.x	Reactive Energy Import In Tariff x
4.8.0	Reactive Energy Export Total
4.8.x	Reactive Energy Export In Tariff x
5.8.0	Reactive Energy Inductive Import (Q1) Total
5.8.x	Reactive Energy Inductive Import (Q1) In Tariff x
6.8.0	Reactive Energy Capacitive Export (Q2) Total
6.8.x	Reactive Energy Capacitive Export (Q2) In Tariff x
7.8.0	Reactive Energy Inductive Export (Q3) Total
7.8.x	Reactive Energy Inductive Export (Q3) In Tariff x
8.8.0	Reactive Energy Capacitive Import (Q4) Total
8.8.x	Reactive Energy Capacitive Import (Q4) In Tariff x
F	Fatal Error

Table 1 – Display Of Register Codes

Scroll Key

The meter is equipped with two mechanical keys on the meter cover.

Key Function:

- LCD Test
- As an option data defined in auto scroll and manual scroll sequenced can be displayed even when there is no voltage in the network or the meter is not connected

Inputs and Outputs

Inputs

The meter is equipped with one (two-rate meters) or two (3- and 4-rate meters) tariff inputs that are used for external tariff changeover with a phase voltage or network.

Outputs

The meter is equipped with one or two impulse outputs. Two impulse outputs are in case of bi-directional energy flow (an output for each energy flow direction). Outputs can be an S0 (DIN 43864) or opto-MOS relay type. Opto-MOS is required for building management systems.

MT172 Internal Time Switch Real Time Clock

A real time clock is driven by a 32 kHz oscillator. The clock accuracy complies with the requirements stated in the IEC 62052-21 standard. A source for a back-up power supply is built into the meter. It is performed by uninterchangeable LiSOCL2 battery and assures energy up to 3 years of the clock operation in case of a complete power supply failure. Its lifetime is 20 years.

The real time clock generates:

- A tariff program, seasons changeover, transition to day light saving period and vice-versa.

Maintenance

The meter is designed and manufactured in such a way that it does not need any maintenance interventions in the entire lifetime. Measuring stability assures that no recalibration is required. If battery is built onto the meter, its capacity is sufficient to back up all functions for the entire meter lifetime.

Battery capacity assures 3 years of operation in a voltage-free state and 20 years of lifetime.

The Meter Programming

The meter MT171 and MT172 can be programmed to show many different features on the display (please see page 2, Data Display On LCD). It is up to the customer to advise what features are required and if any tariffs are required, the number of tariffs and the times the tariffs must operate at. Autometers has a standard set up showing the following features on the display if none are requested at time of purchase.

MT171

Automatic data scroll

1.8.0 kWh. Reading only

Manual (triggered by pressing the blue key)

- 1.8.0 Positive active energy Total
- 1.8.1 Positive active energy Tariff 1 (operates by external time switch)
- 1.8.2 Positive active energy Tariff 2 (operates by external time switch)
- 2.8.0 Negative active energy Total
- F Fatal error / Display test all digits illuminate / End

If meter is supplied with Optomos Relay (Volt Free) the pulse value is programmed in at 10 imp/kWh

MT172

Automatic data scroll

1.8.0 Positive active energy Total

Manual (triggered by pressing the blue key)

- 0.9.1 Time
- 0.9.2 Date YY-MM-DD
- 1.8.0 Positive active energy Total
- 1.8.1 Positive active energy Tariff 1 (If time supplied)
- 1.8.2 Positive active energy Tariff 2 (If time supplied)
- 1.8.3 Positive active energy Tariff 3 (If time supplied)
- 1.8.4 Positive active energy Tariff 4 (If time supplied)
- 2.9.0 Negative active energy Total
- 3.8.0 Reactive energy import Total
- F Fatal error / Display test all digits illuminate / End

If meter is supplied with Optomos Relay (Volt Free) the pulse value is programmed in at 10 imp/kWh

Installation Of The Meter

Location

The meters should be mounted in a dry, dirt free environment away from heat sources and very high electric fields. Temperatures should not exceed 70°C or fall below -20°C.

THE METERS MUST BE INSTALLED BY A COMPETENT AND FULLY QUALIFIED ELECTRICIAN

TECHNICAL AND INSTALLATION PUBLICATION MT171, MT172: 01.01.07
Product development is continuous and Autometers Systems Ltd reserves the right to make alterations and manufacture without notice. Products as delivered may therefore differ from the descriptions and illustrations in this publication.

Whole Current Diagram

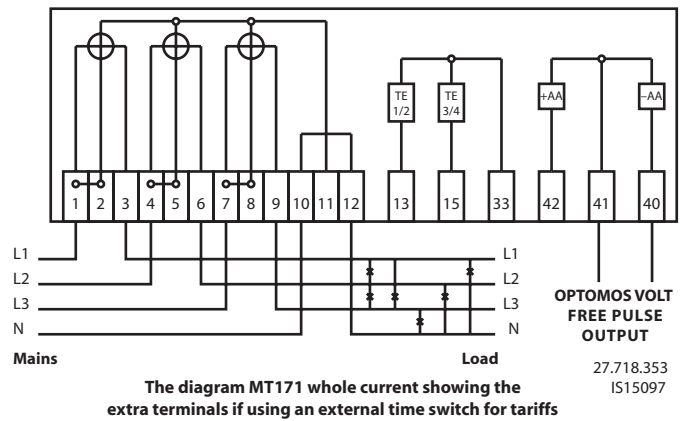

C.T. Operated Diagram

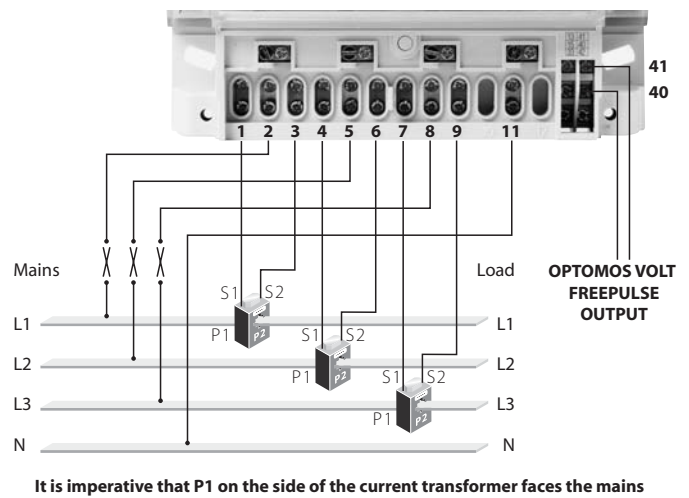

Casing Dimensions

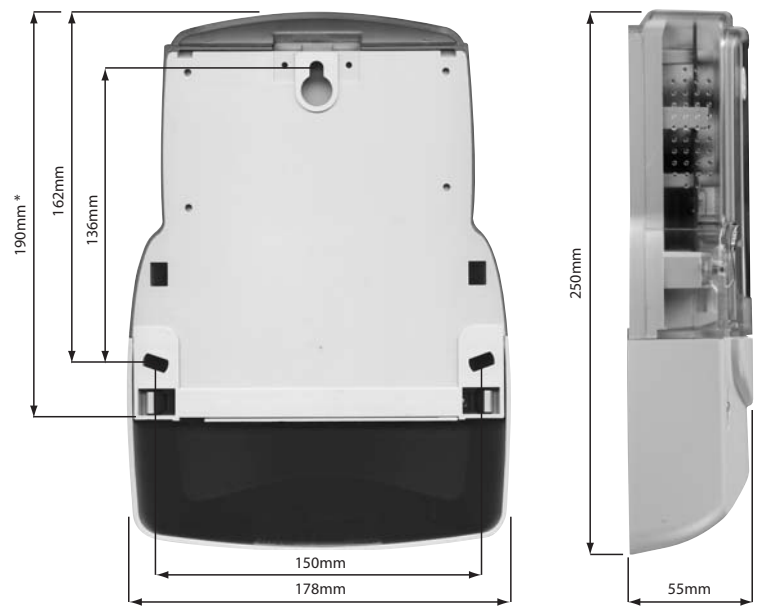

* If fitted with short terminal cover



Autometers Systems Limited,
4B Albany Road,
Chorlton-cum-Hardy,
Manchester.
M21 0AW

Tel: +44 (0) 161 861 9056
Fax: +44 (0) 161 881 3745
www.autometers.co.uk
Email: sales@autometers.co.uk